



**ULTIMATRON  
FRANCE**

**5 YEARS  
WARRANTY**

# Technical sheet

ULTIMATRON LiFePO4 Smart BMS RV Underseat Lithium Battery  
ULS-12-100H (with Heater)



Note: Series and parallel connection for 12V, 24V, 36V, 48V applications.

## Integrated Battery Management System (BMS)

To allow the control and the charge of the different elements of an accumulator battery and to protect it against overcharging, overvoltages and overheating.



## Heating Features

- ★ The integrated heating function starts automatically at temperatures below 0°C when an external charging current (around 7A) is applied. The integrated heating function will not consume the energy from the battery.
- ★ Integrated Heating foils, the battery can be charged at the extreme environment in **-35°C**.

## Compared with traditional batteries, our lithium iron phosphate batteries (LiFePO4) have many advantages:

- 5 years manufacturer's warranty
- The safest technology, without risk of fire or explosion
- Long service life
- Constantly improving storage capacity
- High stability even under extreme loads
- No memory effect, no need for full charge and discharge cycles
- High performance even under extreme conditions
- Deep and regular discharge and charging efficiency

## Integrated Bluetooth 4.0 monitoring



You have all important battery data always on your smartphone or tablet. The application displays the data in real time.

MARQUE FRANÇAISE





### ULTIMATRON LiFePO4 Smart BMS RV Underseat Lithium Battery ULS-12-100H (with Heater)

#### ELECTRICAL PERFORMANCE

Nominal Voltage	12.8V
Nominal Capacity	100Ah
Capacity @ 20A	300min
Energy	1280Wh
Resistance	≤15 mΩ @ 50% SOC
Self Discharge	<3% / Month
Number of Cycles	>6000@80%D.o.D

#### CHARGE PERFORMANCE

Recommended Charge Current	30A
Maximum Charge Current	50A
Recommended Charge Voltage	14.6V
Charge Cut-Off Voltage	14.6V (2000ms)
Reconnect Voltage	≤13.8V
Balancing Voltage	>12.8V

#### DISCHARGE PERFORMANCE

Maximum continuous Discharge Current	150A
Peak Discharge Cut-Off Current	450A (200 ~ 500 ms)
Discharge Cut-Off Voltage	10V (2000 ms)
Reconnect Voltage	>11.2V
Short Circuit Protection	1000-2000A ± 400A (200 ~ 800 μs)

#### TEMPERATURE PERFORMANCE

Discharge Temperature	-20 ~ 75 °C
Charge Temperature	0 ~ 50 °C ❄️
Heater Working Temperature	-35 ~ 5 °C ❄️
Storage Temperature	-5 ~ 35 °C

#### DIMENSION

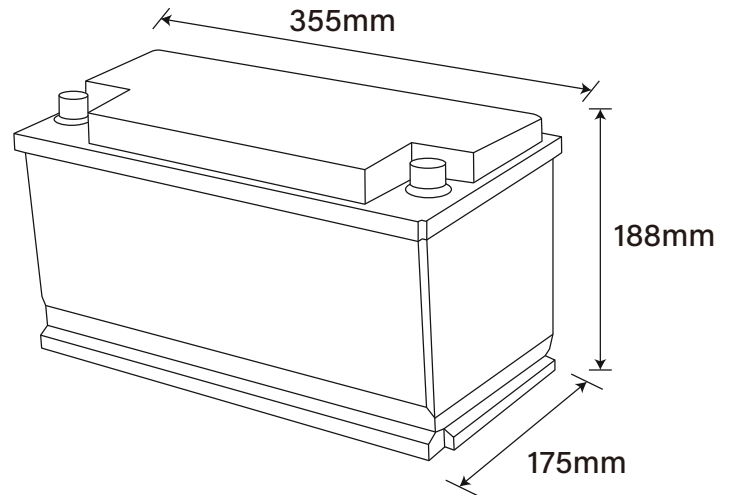

DIN Standard Dimensions L355 \* W175 \* H188 mm

#### MECHANICAL PERFORMANCE

Weight	12.6kg
Terminal Type	SAE
Terminal Torque	80 ~ 100 in-lbs (9 ~ 11 N-m)
Case Material	ABS
Ingress Protection Code	IP65
Bluetooth	Bluetooth 4.0 with smartphone app
Heating Foil	80W

#### COMPLIANCE

Certifications	CE UN38.3 UL1642 & IEC62133
Shipping Classification	UN 3480, CLASS 9