

FM7 BACK FM7 TOP

indelB

istruzioni per l'uso

instructions for use

instrucciones de uso

instructions d'utilisation

bedienungsanleitung



Attention: carefully read this instructions manual and the safety warnings before using the device, to prevent risks to the installer, user or any possible third party.

SYMBOLS CONTAINED IN THIS MANUAL

During the creation of this manual, the symbols contained in the following list have been added to: make the actions to be done more understandable; find measures to get the best performances from the device.



Generic warning signal. It indicates a caution to be put in action.



Warning about system disposal (Directive 2012/19/EU).

SYMBOLS LOCATED ON THE DEVICE



Manufacturer.



Product code.



Serial number.



Signal for a generic required behaviour.



Refer to the Instructions Manual. Follow the Instructions for use.

IPN₁N₂

IP protection levels (Ingress Protection).

First characteristic digit N₁: protection against the penetration of solid bodies, including dust;

Second characteristic digit N₂: protection against harmful penetration of water. Protected against the penetration of solid foreign bodies with 12.5 mm diameter and higher

N₁ = 2

N₂ = 0

Not protected

FM 7



Declaration of conformity and identification of the certifying body, according to the Medical Directive 93/42/EC



Do not use if the package is damaged.



Protect from direct sunlight.



Protect against humidity.



Storage temperature limits.



Fragile.



Top.

TECHNICAL DESCRIPTION

The refrigerator in this manual, also called "device", generates cold by vaporizing at a low pressure a liquid refrigerant fluid, HFC, within a thermal exchanger (evaporator). The steam obtained that way is then made liquid again by means of a mechanical compression with a higher pressure (by means of a compressor), followed by a cooling down performed in another thermal exchanger (condenser). The correct and uniform distribution of the air inside the refrigerated chamber is guaranteed by a electrical fan.

The device is made of a modular monocoque, covered with suitable and diversified materials and insulated with expanded polyurethane with a density of 42 kg/ m³.

Displays and dials are all located in the front panel.

The refrigerated chamber is equipped with racks, that serve as a support for wire shelves (grid).

LIST OF THE MAJOR ASSEMBLIES

- 1 - stainless steel frame;
- 2 - a door to access the internal compartment, made of stainless steel;
- 3 - an internal cooled compartment, including an retaining wall compartment for products, provided with a grid;
- 4 - refrigerating unit with compressor; which can be removed and operated in remote mode, if required;
- 5 - control panel.

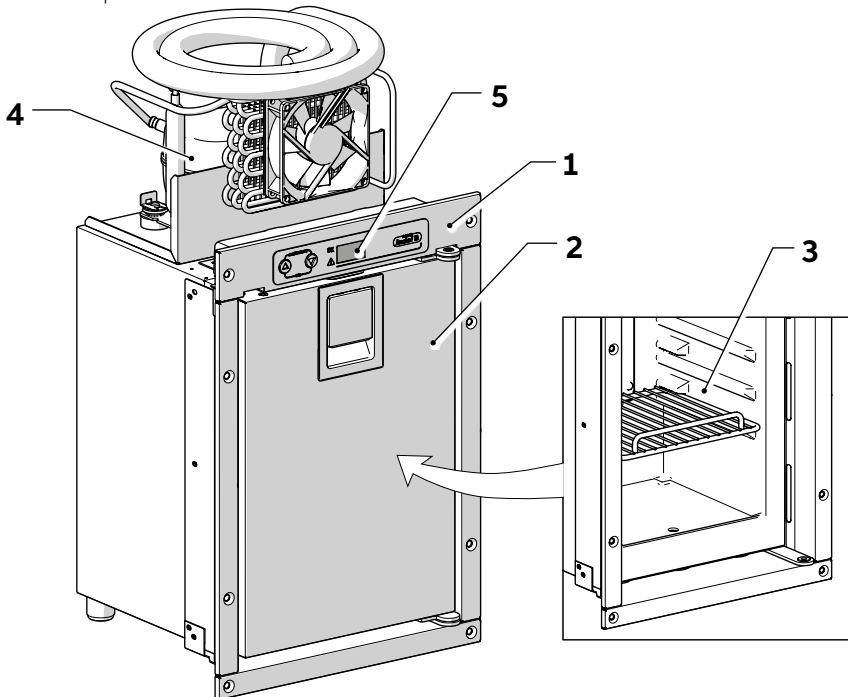

FM 7

INTENDED USE

The FM7 refrigerator is a piece of professional equipment which can only be installed into a motor vehicle. It is particularly appropriate for emergency vehicles like ambulances, according to the EN 60601-1 standard. The use of the refrigerator FM7 is reserved only to medical and sanitary personnel.

It is operated by 12/24 V DC supply voltage, directly drawn from the battery of the vehicle.

It can cool products and keep them cool at stable temperature which can be set between 2 °C and 8 °C with a tolerance of $\pm 1.5^\circ\text{C}$.

Make sure that only products that can be cooled at reference temperatures are stored in the device: see TECHNICAL DATA table.



Based on the Directive 2007/41/EEC and 93/42/EEC, the class I devices are destined to:

- Preserve correctly packaged drugs, vaccines and reagents, other than body fluids or body tissues, destined to be administrated or introduced into the human body.
- Preserve other not flammable nor explosive substances or materials for a generic use in environments like hospitals, pharmaceutical centres or laboratories.

These devices are not destined to preserve blood, body fluids or body tissues.

TECHNICAL DATA

MODEL	FM7
Volume of the cooled compartment	7 litres
Net weight	10.9 Kg
Outside dimensions (HxLxD)	See figure "Overall dimensions"
Average power requirements	56 - 67 W
Supply voltage	DC 12/24 V
Fixed point temperature	4 °C \pm 1.5 °C
Climate Class	SN - ST 10 \div 38 °C
Refrigerant gas	R134a 0,035 kg - CFC Free (CO ₂ eq. 0,050 t)

This device contains fluorinated greenhouse gas R134a in a hermetically sealed system which operates in relation to the presence of this gas.

ABBREVIATIONS

kg.....Kilogram.....unit of measure of the mass

W.....Watt.....unit of measure of the power

DC.....Direct current

V.....Volt.....unit of measure of the operating electrical voltage

°C.....Degrees Celsius.....unit of measure of the temperature in a Celsius scale

R134a.....HFC 1,1,1,2 Tetrafluoroethane C₂H₂F₄ - CAS Number 811-97-2 - CE Number 212-377-0

FM7 REV. 02 - 01_2022

OVERALL DIMENSIONS

FM7 BACK

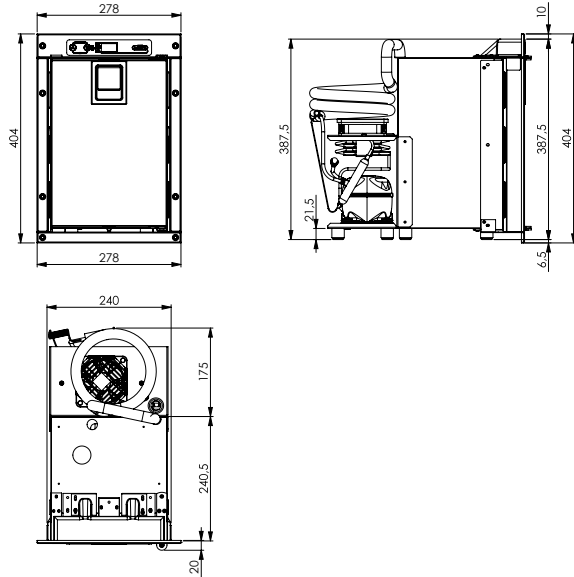

FM7 TOP

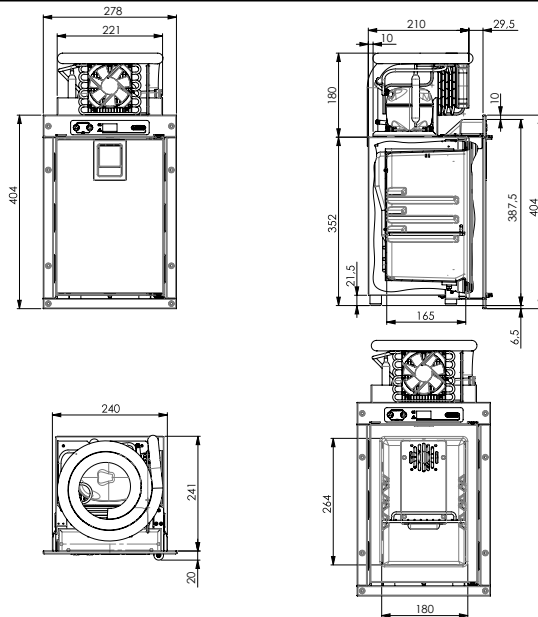

FM 7

SAFETY

The following paragraph lists a short description of all the safety standards adopted while designing the device. Also, all safety precautions to be taken during use are described as well, for a proper use of the device.

GENERAL SAFETY

The refrigerator FM7 complies with the following standards:

Directive 93/42/EEC dated 14 June 1993: General criteria regarding design and construction of some categories of medical devices.

DM 15 November 2005: Approving the templates for the information cards in case of accidents or missed accidents involving medical devices or medical devices in vitro.

DM 20 February 2007: New modes for the requirements stated in art. 13 of the legislative decree 24 February 1997, no. 46 e following amendments and for the registration of the active implantable devices and the transcription in the List of medical devices.

DM 21 December 2009: Changes and integration to the Decree 20 February 2007 containing "New modes for the requirements stated in art. 13 of the legislative decree 24 February 1997, no. 46 e following amendments and for the registration of the active implantable devices and the transcription in the List of medical devices.

MedDev 2.4/1 rev. 9 June 2010: Classification of medical devices.

MedDev 2.7/1 rev. 4 June 2016: Clinical evaluation: a guide for manufacturers and notified bodies.

MedDev 2.12 rev. 8 January 2013: Guidelines on a Medical Devices Vigilance System

UNI EN ISO 9001:2015: Template for quality assurance during design, development, manufacture, installation and service.

UNI EN ISO 9000:2015: Quality management systems – Fundamentals and vocabulary

UNI ENI CEI EN ISO 14971:2012: Medical devices – Application of the risk management to medical devices.

CEI EN 60601-1:2007: Electro medical equipment – Part 1: General prescriptions about the fundamental safety and the essential performance.

CEI EN 60601-1-2:2015: Electro medical equipment - Part 1: General prescriptions about the fundamental safety and the essential performance - Collateral standard Electromagnetic compatibility - Prescriptions and proofs

CEI EN 60601-1-6:2010: Electro medical equipment - Part 1: General prescriptions about the fundamental safety and the essential performance - Collateral standard Usability

CEI EN 60601-1-8:2007: Electro medical equipment – Part 1: General prescriptions about the fundamental safety and the essential performance – Collateral standard Alarm systems.

CEI EN 62304:2015: Medical device software – software life-cycle processes.

CEI EN 62353:2015: Electro medical equipment – Periodical checks and tests to be done after the repair of an electro medical equipment.

CEI EN 62366-1:2015: Electro medical devices – Part 1: Application of the engineering to the usability of the medical devices.

UNI EN 1041:2013: Information supplied by the manufacturer together with the medical devices.

UNI CEI EN ISO 15223:2017: Medical devices – Symbols to be used in the labels of the medical device, in the labelling and in the information that must be supplied with it– Part 1: General requirements

GENERAL SAFETY WARNINGS

The Manufacturer is responsible for the safety, reliability and performance of the device, only if the following conditions are met.



The device must be used in compliance with the instructions contained in this manual, referring both to the safety precautions and the use of the device itself;



the installation and any operation of repair, modification and service must be done by qualified personnel;



the electric system where the device is destined to must be compliant both to the IEC requirements and to the local currently in force rules.

The Manufacturer reserves the right to deliver, after written request by authorized servicing personnel, the following items: electric diagrams, component lists and any information related to the single parts of the device, considered by the Manufacturer as able to be repaired.



Attention

The Manufacturer shall not be held responsible for personal or property damages deriving from the conditions indicated below:

- improper installation or connection;
- damages the device, due to external mechanical effects or overvoltage;
- changes to the device without the Manufacturer's express written consent;
- use and maintenance, not compliant with the contents of this manual, for uses different from the ones described in the paragraph Intended use, and the lack of adoption by the user of all cautions, measures and safety standards necessary to prevent any prejudice.



Attention

Strictly follow the indications given below:

- Do not operate the device if its structure or the cooling circuit is visibly damaged.
- The operators that are not able to safely use the device due to their physical, sensory or mental capacities, or to their poor experience or knowledge must not use the device, unless a person responsible for them is present. Otherwise, they must follow the indications of this person.
- Install the device in a dry place protected by water jets.
- Do not install the device next to heat sources like: heating elements, intense exposure to sunlight, electric ovens and gas ovens.
- Do not obstruct ventilation grilles.
- Do not store corrosive substances or solvents in the device.
- Do not store explosive substances, such as spray cans, containing propellant gases.
- Before operating the device, make sure that voltage in the battery corresponds to the operating value.
- If the power supply cable is damaged, immediately replace it with a cable having the same technical specifications (cross-section, length, insulation).
- Do not touch the device with bare hands or wet hands, and having bare or wet feet.
- Do not insert screw drivers or other tools between the protections or the moving parts of the device.
- Only skilled personnel must repair the device, so as to avoid high risks for the health of the users. Contact the Manufacturer's After-Sales Service.

FM 7

SAFETY WARNINGS DURING USE



Attention

Strictly follow the indications given below:

- Keep and use the device away from children.
- Protect the device and cables from excessive heat and from moisture.
- Disconnect the device from the power supply battery when recharging the battery, as overvoltage may damage it.
- If the device is not used for a long time, disconnect it from the battery and dry the internal compartment.

INSTALLATION



Carefully read and comply with the following instructions, to perform a correct installation of the device in a proper way and to avoid risks to the installer and to any third party.

CHECKING THE RECEIVED GOODS



In presence of the carrier, inspect the goods received for its integrity and state.

Check the correspondence between the contents of the delivery and the items listed in the delivery bill.

In case of discrepancies and/or damages detected, claim the situation to the carrier.

NOTE: According to the national and international laws, goods are always travelling at consignee's risk. If not otherwise stated in the contract, goods are transported without assurance, at consignee's risk. Any claim due to damages suffered during the shipment, transportation, unloading and unpacking of the device may not be imputed to the Manufacturer.

INSTALLATION WARNING



Follow the indications given below for proper set-up and selection of the installation site:

- Do not install the device next to heat sources like heating elements, electric ovens and gas ovens, hot water pipes.
- Install the device in a dry and protected place.
- Install the device so that hot air produced by the cooling circuit can be freely dissipated. Therefore, ensure adequate ventilation respecting the distances from the retaining walls, indicated in the figure below.
- Install the device so that the refrigerating unit is inaccessible to every unauthorized user. When the refrigerating unit is operating, its components may get overheated and create a danger for the user.
- The device shouldn't share the electric power supply line with other equipment able to create overvoltage peaks in a fast and destroying way. In an ideal condition, the device should be supplied

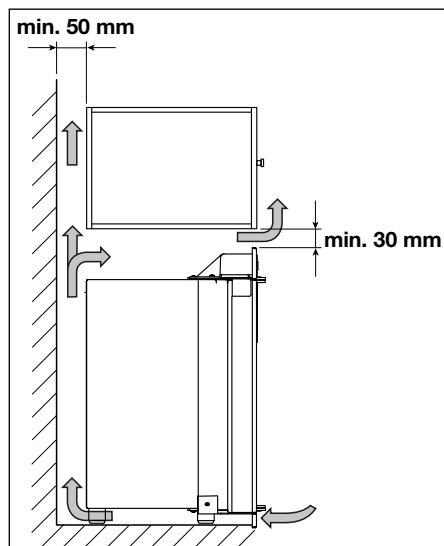

by a dedicated electric line and have a dedicated circuit breaker. In situations of voltage peaks on the power supply mains, due to direct or indirect lightning, the device can get blocked. Try to reset the device and, if the block persists, contact the authorized After-Sales Service Centre.

- Do not use the device near or stacked over other equipment. Should this condition not be possible, check the correct operation of the device itself, in the configuration where it is being used.

TRANSPORTATION AND DISPLACEMENT



The device must be transported and moved only while in vertical position, respecting the indications on its packaging. This precaution is necessary to avoid the circulation of the compressor oil, which could damage the valves and coils, and create starting problems to the electric motor. The Manufacturer shall not be liable for problems due to a transportation made in a way different from what stated here.

INSTALLING THE REFRIGERATOR IN A VEHICLE



Attention: Before fastening the device, make sure that the chosen position is suitable to contain it, and that the correct ventilation is assured.

To fasten the device, having it inserted in a compartment inside a vehicle, fasten the stainless steel frame (flange) to the sides of the compartment using eight self-threading screws, with 5.5 mm diameter and flat countersunk head, as shown in figure.



Attention: After installation of the device, before putting it in operation, check its stability and its complete fastening to the vehicle.

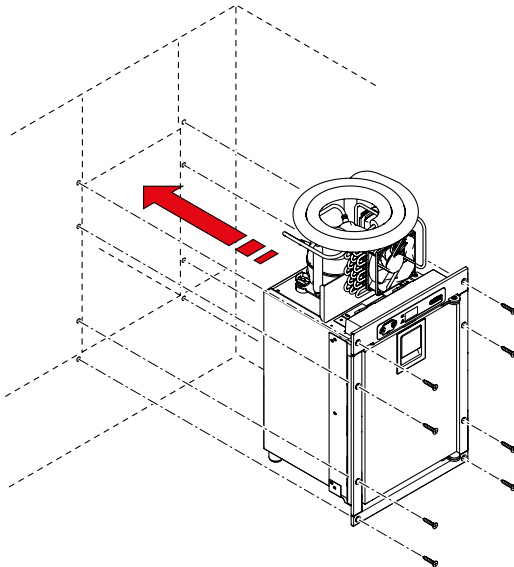

FM 7

REMOVING AND REMOTELY CONTROLLING THE COOLING UNIT

The entire cooling unit **1** can be removed if required, and then it can be placed in a remote position in relation to the device, at a maximum distance of 1.5 meters.

Remove the cooling unit as directed below:

- For **FM7 TOP** loosen the four screws **2A** using a long cross-head screwdriver.
- For **FM7 BACK** loosen the six screws **2B** using a long cross-head screwdriver.
- Raise the cooling unit **1** and slowly unwind the suction hose **3**.
- Install the cooling unit **1** in a stable and protected position.

FM7 BACK

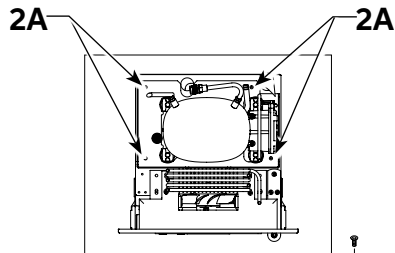
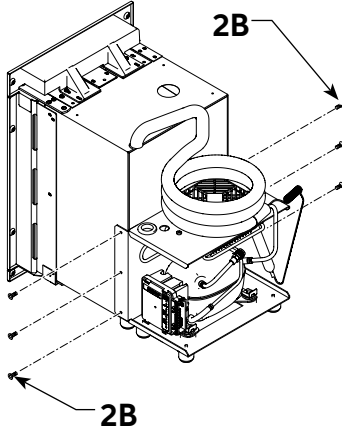

FM7 TOP

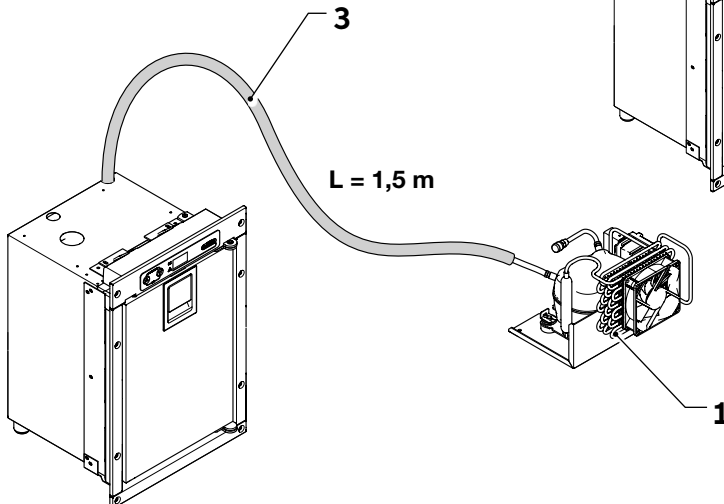
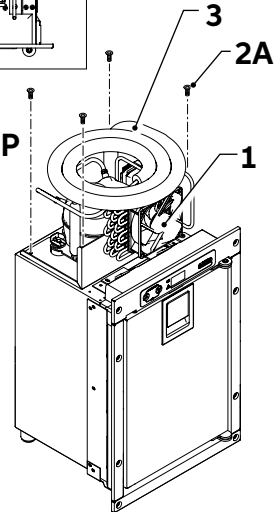



Attention: The refrigerating unit must always be inaccessible to every unauthorized user. When the refrigerating unit is operating, its components may get overheated and create a danger for the user.



Attention: Remote control of the refrigeration unit counts as a modification of the device that could compromise its immunity, electromagnetic compatibility and mechanical resistance.



Check that the device is working properly in terms of immunity, electromagnetic compatibility and mechanical resistance in the configuration in which it is used.

FM 7

REVERSING THE OPENING SIDE OF THE DOOR

The opening side of the door can be reversed from right to left or vice versa if required.

Proceed as directed below to reverse the opening of the entire door unit:

- Remove the bottom flange **1** by loosening the four fixing screws, two for each side.
- Remove the hinges **2** and **3** secured to the frame of the device by loosening the fixing screws.
- Remove the "L"-shaped bracket **4** in position **C** by loosening the fixing screws.
- Remove the hinges **5** and **6** secured to the door of the device by loosening the fixing screws.
- Remove the plugs **7**.
- Install in position **C** the hinge of the door that was previously in position **A**.
- Install in position **D** the hinge of the door that was previously in position **B**.
- Install the plugs **7** and install the "L"-shaped bracket **B** in its position **4**.
- Install the hinges previously secured to the frame in the opposite side (positions **C** and **D**).
- Secure the bottom flange **1** to the frame of the device.

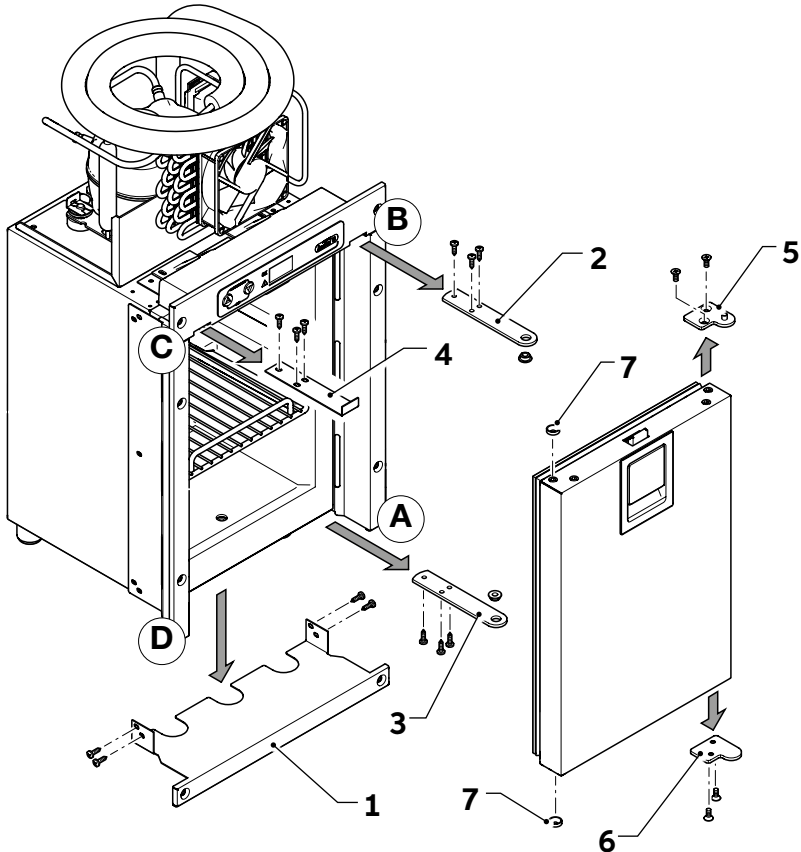

FM7 REV. 02 - 01_2022

CONNECTING THE DEVICE TO THE POWER SUPPLY BATTERY

The device is operated at **12/24 Volt DC**.



Attention

The power supply cable must be as short as possible and not interrupted so as to avoid any voltage loss or power loss. Do not use additional switches, plugs, and junction boxes.



Attention

When connecting the battery, make sure that polarity is respected and protect power supply with a 15 A fuse.



Attention

Before charging the battery with a fast battery charger, disconnect the power supply cable of the device and other points of use, if any. Overvoltage may damage the electronic system of the device.

The device is protected by an additional fuse of 7.5 A on the power supply line. In case of fuse blown, remove it and introduce a new one.



Always switch the device off and disconnect it from the power supply line before controlling or replacing the fuses.

In case of lack of operation from the device, always check the fuse integrity.

The damaged fuse (blown) must be replaced by a fuse having the same technical characteristics.

COMPRESSOR STATION

Functions and features.

The compressor station is an electronic device which has the function of piloting the motor of the compressor and carrying out all the controls and electrical protection of the system.

Its main features are as follows:

Protection of the battery through automatic turning off of the compressor when the feeding voltage reaches the minimum threshold.

The compressor will start up again automatically when the voltage goes back to normal values.

Note: these values have been measured at control unit input and/or on the DC socket.

BATTERY PROTECTION LEVEL

BATTERY PROTECTION	12V	24V
CUT-OUT	10.4 V (± 0.3 V)	21.3 V (± 0.3 V)
CUT-IN	11.7 V (± 0.3 V)	22.6 V (± 0.3 V)

FM 7

LIST OF ERRORS

Any errors are displayed on the display with the following codes:

NUMBER OF FLASHES	ERROR TYPE
R0.1	Battery protection cut-out (The voltage is outside the cut-out setting)
R0.2	Fan over-current cut-out (The fan loads the electronic unit with more than $1A_{pp}$)
R0.3	Motor start error (The rotor is blocked or the differential pressure in the refrigeration system is too high (>5 bar))
R0.4	Minimum motor speed error (If the refrigeration system is too heavily loaded, the motor cannot maintain minimum speed 1,850 rpm)
R0.5	Thermal cut-out of electronic unit (If the refrigeration system has been too heavily loaded, or if the ambient temperature is high, the electronic unit will run too hot)
R0.6	Communication error (There is no communication between the display and the central control unit)
R0.7	Faulty temperature sensor, or not properly connected to the control unit

USING THE DEVICE



Attention

Before the first start-up of the device, clean the inside with water and neutral detergent and dry with a soft cloth.



Attention

The compressor of the cooling circuit starts approximately 60 seconds after the device has been started.

ENERGY-SAVING TIPS



- Place the device in a well ventilated place protected from sunlight.
- Do not open the device door more often than required: every opening generates a change in the internal temperature and causes the build up of ice.
- Do not leave the door open longer than required.
- Defrost the device at regular intervals, however as soon as the ice layer can be seen.

DEFROSTING THE DEVICE



Inside the device or in the refrigerated compartment, or on the evaporator, frost can build up due to humidity, that reduces the capacity of refrigeration. Periodically defrost the device, as early as possible to prevent the reduction of the capacity of refrigeration.

Proceed as follows for the regular defrosting of the device:

- Remove the products stored inside and place them into another refrigerator, so that storage temperature can be ensured.
- Open the door of the device to melt the layer of ice.



Attention

Do not use hard and/or sharp objects to remove the layer of ice and release the frozen products.

- Dry condensation with a soft cloth and close the door.

FM 7

DESCRIPTION OF THE CONTROL PANEL

- 1 SET button - Alarm reset or temperature increase
- 2 SET button - Alarm reset or temperature decrease. ON/OFF of the device
- 3 Display
- 4 Green led for proper operation
- 5 Red alarm led

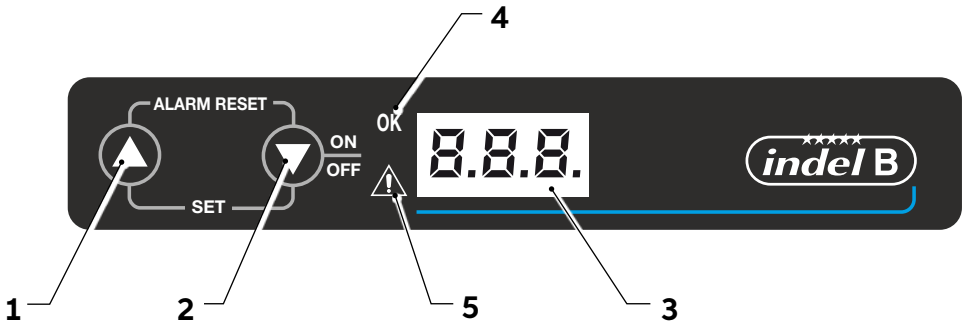

USE OF THE CONTROL PANEL

- To turn the device on, press the button **2**.
- To switch it off, press the button **2** for 5 seconds.
- When the green LED **4** is flashing on and off, the device is reaching its operating temperature and is not yet ready for operation.
- As soon as the device reaches the preset operating temperature, the light of the green led **4** is steady; the device is ready to be used.

SETTING INTERNAL TEMPERATURE

- Simultaneously press buttons **1** and **2** for 10 seconds to enter the temperature adjustment function: the display **3** with the set temperature flashes.
- Use the keys **1** and **2** separately to increase or decrease the temperature to be set.
- Do not press any key when the desired temperature is reached (between 2 °C and 8 °C): the preset value is automatically saved.

ALARM

If the preset temperature varies more than ± 1.5 °C, the red led **5** comes on and flashes intermittently. At the same time an audible alarm (buzzer) is activated.

Check and eliminate the cause of temperature change and press keys **1** and **2** at the same time to deactivate the alarm state.

MAINTENANCE



Attention

Cut power off before performing any operation on the device.



Attention

Regularly perform the maintenance operations described here below and have them done only by qualified and authorized personnel.

CLEANING



Respect the following cleaning operations for a correct maintenance of the device:

- Regularly clean the inside and outside of the device using only warm water and a neutral detergent. Aspirate any solid residual (dust, particles, etc.).
- After washing, rinse with clear water and dry with a soft cloth.
- Avoid penetration of the cleansing agent through the hollow spaces or the openings of the device.
- Do not use: specific products for glass and mirrors; liquid, powder or spray detergents; solvents; alcohol; ammonia or abrasive products.
- When the device is not used, dry the inside and leave the door partially open to ensure ventilation.
- After it has been used for a long time, make sure dust does not obstruct the ventilation grilles.
- Keep the door seal free from mold and oil. Regularly make sure that no signs of aging are present, so as to avoid poor sealing efficiency.
- Clean the condenser at least once a year.

USEFUL TIPS



If the device fails to operate or operation is irregular, before contacting one of our After-Sales Service Centres, make sure that:

- power supply is provided
- voltage corresponds to the value indicated in the plate
- connections and polarity are appropriate
- the refrigerating unit is not placed close to a heat source
- the fuse of the supply line is not interrupted.



Attention

Only skilled personnel, or personnel belonging to an After-Sales Service Centre approved by the Manufacturer, must replace the power supply cable.



Attention

Using accessories and cables other than the supplied ones may cause an increase of the electromagnetic emissions or an increase of the electromagnetic immunity of the device.

Indel B shall not be held responsible for the failure to comply with all the regulations indicated in this manual.

FM 7

ONLY FOR SALE WITHIN THE EUROPEAN COMMUNITY (EU)

This device is marked in compliance with European Directive 2012/19/EU (WEEE). The symbol on the product indicates that it should not be disposed of as household waste. Ensure that this product does not enter the municipal waste disposal system but is disposed of as WEEE for professional use.



ENVIRONMENTAL REQUIREMENTS



Respect the following environmental requirements for a correct maintenance of the device:

- Avoid the presence of corrosive substances such as salts and acids, that can damage the electric components and the plastic parts of the device.
- Reduce as much as possible the build up of dust, as the dust particles may decrease the performance of the refrigerating unit.
- Keep the humidity of the area where the device is in operation between 10% and 80%.
- Keep the temperature of the area where the device is in operation between 10 °C and 38 °C and do not place the device near sources generating changes in the temperature. The storage temperature of the device must be included between 0 °C and 50 °C.



Attention: Health danger!

Make sure that the cooling capacity of the device is appropriate to the preservation of the items you intend to refrigerate.

The device has been designed and manufactured to be able to operate in environments with temperatures included in the Climate Class shown on its Technical Specifications plate. In areas with different characteristics, the performances given by the Manufacturer may not be reached.

Storage temperature	0 °C to 50 °C
Transportation temperature	0 °C to 50 °C
Humidity	10% to 80%
Atmospheric pressure	70000 Pa to 106000 Pa